

# Test Bank

## Questions for Chapter 1

What is the negation of the propositions in 1–4?

1. Abby has more than 300 friends on Facebook.
2. Alissa owns more quilts than Federico.
3. A messaging package for a cell phone costs less than \$20 per month.
4.  $4.5 + 2.5 = 6$

In questions 5–9, determine whether the proposition is TRUE or FALSE.

5.  $1 + 1 = 3$  if and only if  $2 + 2 = 3$ .
6. If it is raining, then it is raining.
7. If  $1 < 0$ , then  $3 = 4$ .
8. If  $2 + 1 = 3$ , then  $2 = 3 - 1$ .
9. If  $1 + 1 = 2$  or  $1 + 1 = 3$ , then  $2 + 2 = 3$  and  $2 + 2 = 4$ .

10. Write the truth table for the proposition  $\neg(r \rightarrow \neg q) \vee (p \wedge \neg r)$ .

11. (a) Find a proposition with the truth table at the right.

(b) Find a proposition using only  $p, q, \neg$ , and the connective  $\vee$  that has this truth table.

| $p$ | $\neg p$ | ? |
|-----|----------|---|
| T   | T        | F |
| T   | F        | F |
| F   | T        | T |
| F   | F        | F |

12. Find a proposition with three variables  $p, q$ , and  $r$  that is true when  $p$  and  $r$  are true and  $q$  is false, and false otherwise.

13. Find a proposition with three variables  $p, q$ , and  $r$  that is true when at most one of the three variables is true, and false otherwise.

14. Find a proposition with three variables  $p, q$ , and  $r$  that is never true.

15. Find a proposition using only  $p, q, \neg$ , and the connective  $\vee$  with the truth table at the right.

| $p$ | $\neg p$ | ? |
|-----|----------|---|
| T   | T        | F |
| T   | F        | T |
| F   | T        | T |
| F   | F        | F |

In 16–17, use the conditional-disjunction equivalence to find an equivalent compound proposition that does not involve conditions.

16.  $\neg p \rightarrow q$

17.  $p \rightarrow (p \wedge q)$

18. Determine whether  $p \rightarrow (q \rightarrow r)$  and  $p \rightarrow (q \wedge r)$  are equivalent.

19. Determine whether  $p \rightarrow (q \rightarrow r)$  is equivalent to  $(p \rightarrow q) \rightarrow r$ .

20. Determine whether  $(p \rightarrow q) \wedge (\neg p \rightarrow q) \equiv q$ .

21. Write a proposition equivalent to  $p \vee \neg q$  that uses only  $p, q, \neg$ , and the connective  $\wedge$ .

22. Write a proposition equivalent to  $\neg p \wedge \neg q$  using only  $p, q, \neg$ , and the connective  $\vee$ .

23. Prove that the proposition “if it is not hot, then it is hot” is equivalent to “it is hot.”
24. Write a proposition equivalent to  $p \rightarrow q$  using only  $p, q, \neg$ , and the connective  $\vee$ .
25. Write a proposition equivalent to  $p \rightarrow q$  using only  $p, q, \neg$ , and the connective  $\wedge$ .
26. Prove that  $p \rightarrow q$  and its converse are not logically equivalent.
27. Prove that  $\neg p \rightarrow \neg q$  and its inverse are not logically equivalent.
28. Determine whether the following two propositions are logically equivalent:  $p \vee (q \wedge r)$ ,  $(p \wedge q) \vee (p \wedge r)$ .
29. Determine whether the following two propositions are logically equivalent:  $p \rightarrow (\neg q \wedge r)$ ,  $\neg p \vee \neg(r \rightarrow q)$ .
30. Prove that  $(q \wedge (p \rightarrow \neg q)) \rightarrow \neg p$  is a tautology using propositional equivalence and the laws of logic.
31. Determine whether this proposition is a tautology:  $((p \rightarrow q) \wedge \neg p) \rightarrow \neg q$ .
32. Determine whether this proposition is a tautology:  $((p \rightarrow \neg q) \wedge q) \rightarrow \neg p$ .

In 33–39, write the statement in the form “If . . . , then . . . .”

33.  $x$  is even only if  $y$  is odd.
34.  $A$  implies  $B$ .
35. It is hot whenever it is sunny.
36. To get a good grade it is necessary that you study.
37. Studying is sufficient for passing.
38. The team wins if the quarterback can pass.
39. You need to be registered in order to check out library books.
40. Write the contrapositive, converse, and inverse of the following: If you try hard, then you will win.
41. Write the contrapositive, converse, and inverse of the following: You sleep late if it is Saturday.

In 42–44 write the negation of the statement. (Don’t write “It is not true that . . . .”)

42. It is Thursday and it is cold.
43. I will go to the play or read a book, but not both.
44. If it is rainy, then we go to the movies.
45. Explain why the negation of “Al and Bill are absent” is not “Al and Bill are present.”
46. Using  $c$  for “it is cold” and  $d$  for “it is dry,” write “It is neither cold nor dry” in symbols.
47. Using  $c$  for “it is cold” and  $r$  for “it is rainy,” write “It is rainy if it is not cold” in symbols.
48. Using  $c$  for “it is cold” and  $w$  for “it is windy,” write “To be windy it is necessary that it be cold” in symbols.
49. Using  $c$  for “it is cold,”  $r$  for “it is rainy,” and  $w$  for “it is windy,” write “It is rainy only if it is windy and cold” in symbols.
50. Express  $r \oplus d$  in English, where  $r$  is “it is rainy” and  $d$  is “it is dry.”
51. Translate the given statement into propositional logic using the propositions provided: On certain highways in the Washington, DC metro area you are allowed to travel on high occupancy lanes during rush hour only if there are at least three passengers in the vehicle. Express your answer in terms of  $r$ : “You are traveling during rush hour.”  $t$ : “You are riding in a car with at least three passengers.” and  $h$ : “You can travel on a high occupancy lane.”
52. A set of propositions is *consistent* if there is an assignment of truth values to each of the variables in the propositions that makes each proposition true. Is the following set of propositions consistent?
  - The system is in multiuser state if and only if it is operating normally.
  - If the system is operating normally, the kernel is functioning.
  - The kernel is not functioning or the system is in interrupt mode.
  - If the system is not in multiuser state, then it is in interrupt mode.
  - The system is in interrupt mode.
53. What Boolean search could you use to look for web pages about U.S. national forests not in Alaska or Hawaii?

54. On the island of knights and knaves you encounter two people,  $A$  and  $B$ . Person  $A$  says “ $B$  is a knave.” Person  $B$  says “We are both knights.” Determine whether each person is a knight or a knave.
55. On the island of knights and knaves you encounter two people,  $A$  and  $B$ . Person  $A$  says “ $B$  is a knave.” Person  $B$  says “At least one of us is a knight.” Determine whether each person is a knight or a knave.

Questions 56–58 relate to inhabitants of an island on which there are three kinds of people: knights who always tell the truth, knaves who always lie, and spies who can either tell the truth or lie. You encounter three people,  $A$ ,  $B$ , and  $C$ . You know one of the three people is a knight, one is a knave, and one is a spy. Each of the three people knows the type of person each of the other two is. For each of these situations, if possible, determine whether there is a unique solution, list all possible solutions or state that there are no solutions.

56.  $A$  says “I am not a knight,”  $B$  says “I am not a spy,” and  $C$  says “I am not a knave.”
57.  $A$  says “I am a spy,”  $B$  says “I am a spy” and  $C$  says “ $B$  is a spy.”
58.  $A$  says “I am a knight,”  $B$  says “I am a knave,” and  $C$  says “I am not a knave.”

Find the output of the combinatorial circuits in 59–60.

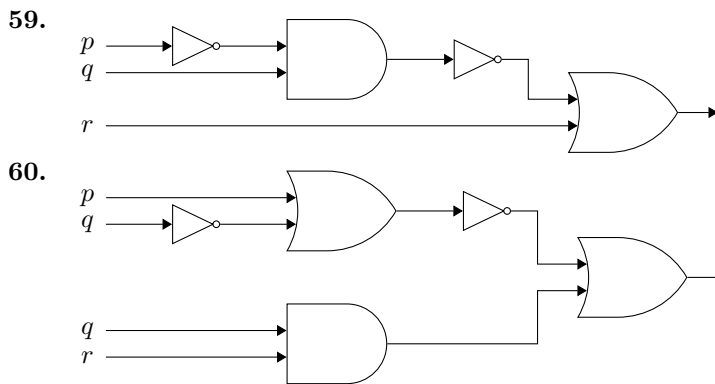

Construct a combinatorial circuit using inverters, OR gates, and AND gates, that produces the outputs in 61–62 from input bits  $p$ ,  $q$  and  $r$ .

61.  $(\neg p \wedge \neg q) \vee (p \wedge \neg r)$
62.  $((p \vee \neg q) \wedge r) \wedge ((\neg p \wedge \neg q) \vee r)$

Determine whether the compound propositions in 63–64 are satisfiable.

63.  $(\neg p \vee \neg q) \wedge (p \rightarrow q)$
64.  $(p \rightarrow q) \wedge (q \rightarrow \neg p) \wedge (p \vee q)$

In 65–67 suppose that  $Q(x)$  is “ $x + 1 = 2x$ ,” where  $x$  is a real number. Find the truth value of the statement.

65.  $Q(2)$
66.  $\forall x Q(x)$
67.  $\exists x Q(x)$

In 68–75  $P(x, y)$  means “ $x + 2y = xy$ ,” where  $x$  and  $y$  are integers. Determine the truth value of the statement.

68.  $P(1, -1)$
69.  $P(0, 0)$
70.  $\exists y P(3, y)$
71.  $\forall x \exists y P(x, y)$
72.  $\exists x \forall y P(x, y)$
73.  $\forall y \exists x P(x, y)$
74.  $\exists y \forall x P(x, y)$
75.  $\neg \forall x \exists y \neg P(x, y)$

In 76–77, express the negation of the statement in terms of quantifiers without using the negation symbol.

**76.**  $\forall x((x > -1) \vee (x < 1))$

**77.**  $\exists x(3 < x \leq 7)$

In 78–79  $P(x, y)$  means “ $x$  and  $y$  are real numbers such that  $x + 2y = 5$ .” Determine whether the statement is true.

**78.**  $\forall x \exists y P(x, y)$

**79.**  $\exists x \forall y P(x, y)$

In 80–82  $P(m, n)$  means “ $m \leq n$ ,” where the universe of discourse for  $m$  and  $n$  is the set of nonnegative integers. What is the truth value of the statement?

**80.**  $\forall n P(0, n)$

**81.**  $\exists n \forall m P(m, n)$

**82.**  $\forall m \exists n P(m, n)$

In questions 83–88 suppose  $P(x, y)$  is a predicate and the universe for the variables  $x$  and  $y$  is  $\{1, 2, 3\}$ . Suppose  $P(1, 3)$ ,  $P(2, 1)$ ,  $P(2, 2)$ ,  $P(2, 3)$ ,  $P(3, 1)$ ,  $P(3, 2)$  are true, and  $P(x, y)$  is false otherwise. Determine whether the following statements are true.

**83.**  $\forall x \exists y P(x, y)$

**84.**  $\exists x \forall y P(x, y)$

**85.**  $\neg \exists x \exists y (P(x, y) \wedge \neg P(y, x))$

**86.**  $\forall y \exists x (P(x, y) \rightarrow P(y, x))$

**87.**  $\forall x \forall y (x \neq y \rightarrow (P(x, y) \vee P(y, x)))$

**88.**  $\forall y \exists x (x \leq y \wedge P(x, y))$

In 88–92 suppose the variable  $x$  represents students and  $y$  represents courses, and:

$$\begin{array}{lll} U(y): y \text{ is an upper-level course} & M(y): y \text{ is a math course} & F(x): x \text{ is a freshman} \\ B(x): x \text{ is a full-time student} & T(x, y): \text{student } x \text{ is taking course } y. & \end{array}$$

Write the statement using these predicates and any needed quantifiers.

**89.** Eric is taking MTH 281.

**90.** All students are freshmen.

**91.** Every freshman is a full-time student.

**92.** No math course is upper-level.

In 93–95 suppose the variable  $x$  represents students and  $y$  represents courses, and:

$$\begin{array}{lll} U(y): y \text{ is an upper-level course} & M(y): y \text{ is a math course} & F(x): x \text{ is a freshman} \\ A(x): x \text{ is a part-time student} & T(x, y): \text{student } x \text{ is taking course } y. & \end{array}$$

Write the statement using these predicates and any needed quantifiers.

**93.** Every student is taking at least one course.

**94.** There is a part-time student who is not taking any math course.

**95.** Every part-time freshman is taking some upper-level course.

In 96–98 suppose the variable  $x$  represents students and  $y$  represents courses, and:

$$F(x): x \text{ is a freshman} \quad A(x): x \text{ is a part-time student} \quad T(x, y): x \text{ is taking } y.$$

Write the statement in good English without using variables in your answers.

**96.**  $F(\text{Mikko})$

**97.**  $\neg \exists y T(\text{Joe}, y)$

**98.**  $\exists x (A(x) \wedge \neg F(x))$

In 99–101 suppose the variable  $x$  represents students and  $y$  represents courses, and:

$$\begin{array}{ll} M(y): y \text{ is a math course} & F(x): x \text{ is a freshman} \\ B(x): x \text{ is a full-time student} & T(x, y): x \text{ is taking } y. \end{array}$$

Write the statement in good English without using variables in your answers.

99.  $\forall x \exists y T(x, y)$   
 100.  $\exists x \forall y T(x, y)$   
 101.  $\forall x \exists y [(B(x) \wedge F(x)) \rightarrow (M(y) \wedge T(x, y))]$

In 102–104 suppose the variables  $x$  and  $y$  represent real numbers, and

$$L(x, y): x < y \quad G(x): x > 0 \quad P(x): x \text{ is a prime number.}$$

Write the statement in good English without using any variables in your answer.

102.  $L(7, 3)$   
 103.  $\forall x \exists y L(x, y)$   
 104.  $\forall x \exists y [G(x) \rightarrow (P(y) \wedge L(x, y))]$

In 105–107 suppose the variables  $x$  and  $y$  represent real numbers, and

$$L(x, y): x < y \quad Q(x, y): x = y \quad E(x): x \text{ is even} \quad I(x): x \text{ is an integer.}$$

Write the statement using these predicates and any needed quantifiers.

105. Every integer is even.  
 106. If  $x < y$ , then  $x$  is not equal to  $y$ .  
 107. There is no largest real number.

In 108–109 suppose the variables  $x$  and  $y$  represent real numbers, and

$$E(x): x \text{ is even} \quad G(x): x > 0 \quad I(x): x \text{ is an integer.}$$

Write the statement using these predicates and any needed quantifiers.

108. Some real numbers are not positive.  
 109. No even integers are odd.

In 110–112 suppose the variable  $x$  represents people, and

$$F(x): x \text{ is friendly} \quad T(x): x \text{ is tall} \quad A(x): x \text{ is angry.}$$

Write the statement using these predicates and any needed quantifiers.

110. Some people are not angry.  
 111. All tall people are friendly.  
 112. No friendly people are angry.

In 113–114 suppose the variable  $x$  represents people, and

$$F(x): x \text{ is friendly} \quad T(x): x \text{ is tall} \quad A(x): x \text{ is angry.}$$

Write the statement using these predicates and any needed quantifiers.

113. Some tall angry people are friendly.  
 114. If a person is friendly, then that person is not angry.

In 115–117 suppose the variable  $x$  represents people, and

$$F(x): x \text{ is friendly} \quad T(x): x \text{ is tall} \quad A(x): x \text{ is angry.}$$

Write the statement in good English. Do not use variables in your answer.

115.  $A(\text{Bill})$   
 116.  $\neg \exists x (A(x) \wedge T(x))$   
 117.  $\neg \forall x (F(x) \rightarrow A(x))$

In 118–120 suppose the variable  $x$  represents students and the variable  $y$  represents courses, and

$A(y)$ :  $y$  is an advanced course     $S(x)$ :  $x$  is a sophomore     $F(x)$ :  $x$  is a freshman     $T(x, y)$ :  $x$  is taking  $y$ .

Write the statement using these predicates and any needed quantifiers.

**118.** There is a course that every freshman is taking.

**119.** No freshman is a sophomore.

**120.** Some freshman is taking an advanced course.

In 121–122 suppose the variable  $x$  represents students and the variable  $y$  represents courses, and

$A(y)$ :  $y$  is an advanced course     $F(x)$ :  $x$  is a freshman     $T(x, y)$ :  $x$  is taking  $y$      $P(x, y)$ :  $x$  passed  $y$ .

Write the statement using the above predicates and any needed quantifiers.

**121.** No one is taking every advanced course.

**122.** Every freshman passed calculus.

In 123–125 suppose the variable  $x$  represents students and the variable  $y$  represents courses, and

$T(x, y)$ :  $x$  is taking  $y$      $P(x, y)$ :  $x$  passed  $y$ .

Write the statement in good English. Do not use variables in your answers.

**123.**  $\neg P(\text{Wisteria, MAT 100})$

**124.**  $\exists y \forall x T(x, y)$

**125.**  $\forall x \exists y T(x, y)$

In 126–130 assume that the universe for  $x$  is all people and the universe for  $y$  is the set of all movies. Write the English statement using the following predicates and any needed quantifiers:

$S(x, y)$ :  $x$  saw  $y$      $L(x, y)$ :  $x$  liked  $y$      $A(y)$ :  $y$  won an award     $C(y)$ :  $y$  is a comedy.

**126.** No comedy won an award.

**127.** Lois saw *Casablanca*, but didn't like it.

**128.** Some people have seen every comedy.

**129.** No one liked every movie he has seen.

**130.** Ben has never seen a movie that won an award.

In 131–133 assume that the universe for  $x$  is all people and the universe for  $y$  is the set of all movies. Write the statement in good English, using the predicates

$S(x, y)$ :  $x$  saw  $y$      $L(x, y)$ :  $x$  liked  $y$ .

Do not use variables in your answer.

**131.**  $\exists y \neg S(\text{Margaret, } y)$

**132.**  $\exists y \forall x L(x, y)$

**133.**  $\forall x \exists y L(x, y)$

In 134–143 suppose the variable  $x$  represents students,  $y$  represents courses, and  $T(x, y)$  means “ $x$  is taking  $y$ .”

Match the English statement with all its equivalent symbolic statements in this list:

- |   |  |  |
|---|--|--|
| 1. $\exists x \forall y T(x, y)$            | 2. $\exists y \forall x T(x, y)$                 | 3. $\forall x \exists y T(x, y)$       |
| 4. $\neg \exists x \exists y T(x, y)$       | 5. $\exists x \forall y \neg T(x, y)$            | 6. $\forall y \exists x T(x, y)$       |
| 7. $\exists y \forall x \neg T(x, y)$       | 8. $\neg \forall x \exists y T(x, y)$            | 9. $\neg \exists y \forall x T(x, y)$  |
| 10. $\neg \forall x \exists y \neg T(x, y)$ | 11. $\neg \forall x \neg \forall y \neg T(x, y)$ | 12. $\forall x \exists y \neg T(x, y)$ |

**134.** Every course is being taken by at least one student.

**135.** Some student is taking every course.

**136.** No student is taking all courses.

**137.** There is a course that all students are taking.

**138.** Every student is taking at least one course.

**139.** There is a course that no students are taking.

**140.** Some students are taking no courses.

141. No course is being taken by all students.  
 142. Some courses are being taken by no students.  
 143. No student is taking any course.

In 144–154 suppose the variable  $x$  represents students,  $F(x)$  means “ $x$  is a freshman,” and  $M(x)$  means “ $x$  is a math major.” Match the statement in symbols with one of the English statements in this list:

1. Some freshmen are math majors.
  2. Every math major is a freshman.
  3. No math major is a freshman.
144.  $\forall x (M(x) \rightarrow \neg F(x))$   
 145.  $\neg \exists x (M(x) \wedge \neg F(x))$   
 146.  $\forall x (F(x) \rightarrow \neg M(x))$   
 147.  $\forall x (M(x) \rightarrow F(x))$   
 148.  $\exists x (F(x) \wedge M(x))$   
 149.  $\neg \forall x (\neg F(x) \vee \neg M(x))$   
 150.  $\forall x (\neg (M(x) \wedge \neg F(x)))$   
 151.  $\forall x (\neg M(x) \vee \neg F(x))$   
 152.  $\neg \exists x (M(x) \wedge \neg F(x))$   
 153.  $\neg \exists x (M(x) \wedge F(x))$   
 154.  $\neg \forall x (F(x) \rightarrow \neg M(x))$

In 155–158 let  $F(A)$  be the predicate “ $A$  is a finite set” and  $S(A, B)$  be the predicate “ $A$  is contained in  $B$ .” Suppose the universe of discourse consists of all sets. Translate the statement into symbols.

155. Not all sets are finite.  
 156. Every subset of a finite set is finite.  
 157. No infinite set is contained in a finite set.  
 158. The empty set is a subset of every finite set.

In 158–163 write the negation of the statement in good English. Don’t write “It is not true that . . . .”

159. Some bananas are yellow.  
 160. All integers ending in the digit 7 are odd.  
 161. No tests are easy.  
 162. Roses are red and violets are blue.  
 163. Some skiers do not speak Swedish.  
 164. A student is asked to give the negation of “all bananas are ripe.”  
 (a) The student responds “all bananas are not ripe.” Explain why the English in the student’s response is ambiguous.  
 (b) Another student says that the negation of the statement is “no bananas are ripe.” Explain why this is not correct.  
 (c) Another student says that the negation of the statement is “some bananas are ripe.” Explain why this is not correct.  
 (d) Give the correct negation.  
 165. Explain why the negation of “Some students in my class use e-mail” is not “Some students in my class do not use e-mail.”  
 166. What is the rule of inference used in the following:  
 If it snows today, the university will be closed. The university will not be closed today. Therefore, it did not snow today.

**167.** What is the rule of inference used in the following:

If I work all night on this homework, then I can answer all the exercises. If I answer all the exercises, I will understand the material. Therefore, if I work all night on this homework, then I will understand the material.

**168.** Explain why an argument of the following form is not valid:

$$\begin{array}{l} p \rightarrow q \\ \hline \neg p \\ \hline \therefore \neg q \end{array}$$

**169.** Determine whether the following argument is valid:

$$\begin{array}{l} p \rightarrow r \\ q \rightarrow r \\ \hline \neg(p \vee q) \\ \hline \therefore \neg r \end{array}$$

**170.** Determine whether the following argument is valid:

$$\begin{array}{l} p \rightarrow r \\ q \rightarrow r \\ \hline q \vee \neg r \\ \hline \therefore \neg p \end{array}$$

**171.** Show that the hypotheses “I left my notes in the library or I finished the rough draft of the paper” and “I did not leave my notes in the library or I revised the bibliography” imply that “I finished the rough draft of the paper or I revised the bibliography.”

**172.** Determine whether the following argument is valid. Name the rule of inference or the fallacy.

If  $n$  is a real number such that  $n > 1$ , then  $n^2 > 1$ . Suppose that  $n^2 > 1$ . Then  $n > 1$ .

**173.** Determine whether the following argument is valid. Name the rule of inference or the fallacy.

If  $n$  is a real number such that  $n > 2$ , then  $n^2 > 4$ . Suppose that  $n \leq 2$ . Then  $n^2 \leq 4$ .

**174.** Determine whether the following argument is valid:

She is a Math Major or a Computer Science Major.  
 If she does not know discrete math, she is not a Math Major.  
 If she knows discrete math, she is smart.  
 She is not a Computer Science Major.  
 Therefore, she is smart.

**175.** Determine whether the following argument is valid.

Rainy days make gardens grow.  
 Gardens don't grow if it is not hot.  
 It always rains on a day that is not hot.  
 Therefore, if it is not hot, then it is hot.

**176.** Determine whether the following argument is valid.

If you are not in the tennis tournament, you will not meet Ed.  
 If you aren't in the tennis tournament or if you aren't in the play, you won't meet Kelly.  
 You meet Kelly or you don't meet Ed.  
 It is false that you are in the tennis tournament and in the play.  
 Therefore, you are in the tennis tournament.

**177.** Show that the premises “Every student in this class passed the first exam” and “Alvina is a student in this class” imply the conclusion “Alvina passed the first exam.”

**178.** Show that the premises “Jean is a student in my class” and “No student in my class is from England” imply the conclusion “Jean is not from England.”



179. Determine whether the premises “Some math majors left the campus for the weekend” and “All seniors left the campus for the weekend” imply the conclusion “Some seniors are math majors.”
180. Show that the premises “Everyone who read the textbook passed the exam,” and “Ed read the textbook” imply the conclusion “Ed passed the exam.”
181. Determine whether the premises “No juniors left campus for the weekend” and “Some math majors are not juniors” imply the conclusion “Some math majors left campus for the weekend.”
182. Show that the premise “My daughter visited Europe last week” implies the conclusion “Someone visited Europe last week.”
183. Suppose you wish to prove a theorem of the form “if  $p$  then  $q$ .”
- If you give a direct proof, what do you assume and what do you prove?
  - If you give a proof by contraposition, what do you assume and what do you prove?
  - If you give a proof by contradiction, what do you assume and what do you prove?
184. Suppose that you had to prove a theorem of the form “if  $p$  then  $q$ .” Explain the difference between a direct proof and a proof by contraposition.
185. Give a direct proof of the following: “If  $x$  is an odd integer and  $y$  is an even integer, then  $x + y$  is odd.”
186. Give a proof by contradiction of the following: “If  $n$  is an odd integer, then  $n^2$  is odd.”
187. Consider the following theorem: “if  $x$  and  $y$  are odd integers, then  $x + y$  is even.” Give a direct proof of this theorem.
188. Consider the following theorem: “if  $x$  and  $y$  are odd integers, then  $x + y$  is even.” Give a proof by contradiction of this theorem.
189. Give a proof by contradiction of the following: If  $x$  and  $y$  are even integers, then  $xy$  is even.
190. Consider the following theorem: If  $x$  is an odd integer, then  $x + 2$  is odd. Give a direct proof of this theorem
191. Consider the following theorem: If  $x$  is an odd integer, then  $x + 2$  is odd. Give a proof by contraposition of this theorem.
192. Consider the following theorem: If  $x$  is an odd integer, then  $x + 2$  is odd. Give a proof by contradiction of this theorem.
193. Consider the following theorem: If  $n$  is an even integer, then  $n + 1$  is odd. Give a direct proof of this theorem.
194. Consider the following theorem: If  $n$  is an even integer, then  $n + 1$  is odd. Give a proof by contraposition of this theorem.
195. Consider the following theorem: If  $n$  is an even integer, then  $n + 1$  is odd. Give a proof by contradiction of this theorem.
196. Prove that the following is true for all positive integers  $n$ :  $n$  is even if and only if  $3n^2 + 8$  is even.
197. Prove the following theorem:  $n$  is even if and only if  $n^2$  is even.
198. Prove: if  $m$  and  $n$  are even integers, then  $mn$  is a multiple of 4.
199. Prove or disprove: For all real numbers  $x$  and  $y$ ,  $\lfloor x - y \rfloor = \lfloor x \rfloor - \lfloor y \rfloor$ .
200. Prove or disprove: For all real numbers  $x$  and  $y$ ,  $\lfloor x + \lfloor x \rfloor \rfloor = \lfloor 2x \rfloor$ .
201. Prove or disprove: For all real numbers  $x$  and  $y$ ,  $\lfloor xy \rfloor = \lfloor x \rfloor \cdot \lfloor y \rfloor$ .
202. Give a proof by cases that  $x \leq |x|$  for all real numbers  $x$ .
203. Use a proof by cases to show that 27 is not the square of a positive integer.
204. Suppose you are allowed to give either a direct proof or a proof by contraposition of the following: if  $3n + 5$  is even, then  $n$  is odd. Which type of proof would be easier to give? Explain why.
205. Prove that the following three statements about positive integers  $n$  are equivalent: (a)  $n$  is even; (b)  $n^3 + 1$  is odd; (c)  $n^2 - 1$  is odd.
206. Given any 40 people, prove that at least four of them were born in the same month of the year.

207. Prove that the equation  $2x^2 + y^2 = 14$  has no positive integer solutions.
208. What is wrong with the following “proof” that  $-3 = 3$ , using backward reasoning? Assume that  $-3 = 3$ . Squaring both sides yields  $(-3)^2 = 3^2$ , or  $9 = 9$ . Therefore  $-3 = 3$ .

### Answers for Chapter 1

1. Abby has fewer than 301 friends on facebook.
2. Allisa does not own more quilts than Federico.
3. A messaging package for a cell phone costs at least \$20 per month.
4.  $4.5 + 2.5 \neq 6$
5. True
6. True
7. True
8. True
9. False

10. 

|     |     |     |   |
|-----|-----|-----|---|
| $p$ | $q$ | $r$ | $\neg(r \rightarrow \neg q) \vee (p \wedge \neg r)$ |
| T   | T   | T   | T   |
| T   | T   | F   | T   |
| T   | F   | T   | F   |
| T   | F   | F   | T   |
| F   | T   | T   | T   |
| F   | T   | F   | F   |
| F   | F   | T   | F   |
| F   | F   | F   | F   |

11. (a)  $\neg p \wedge q$       (b)  $\neg(p \vee \neg q)$
12.  $p \wedge \neg q \wedge r$
13.  $(p \wedge \neg q \wedge \neg r) \vee (\neg p \wedge q \wedge \neg r) \vee (\neg p \wedge \neg q \wedge r) \vee (\neg p \wedge \neg q \wedge \neg r)$
14.  $(p \wedge \neg p) \vee (q \wedge \neg q) \vee (r \wedge \neg r)$
15.  $\neg(\neg p \vee q) \vee \neg(p \vee \neg q)$
16.  $p \vee q$
17.  $\neg p \vee q$
18. Not equivalent. Let  $q$  be false and  $p$  and  $r$  be true.
19. Not equivalent. Let  $p$ ,  $q$ , and  $r$  be false.
20. Both truth tables are identical:
- |     |     |   |     |
|-----|-----|---|-----|
| $p$ | $q$ | $(p \rightarrow q) \wedge (\neg p \rightarrow q)$ | $q$ |
| T   | T   | T   | T   |
| T   | F   | F   | F   |
| F   | T   | T   | T   |
| F   | F   | F   | F   |
21.  $\neg(\neg p \wedge q)$
22.  $\neg(p \vee q)$
23. Both propositions are true when “it is hot” is true and both are false when “it is hot” is false.
24.  $\neg p \vee q$
25.  $\neg(p \wedge \neg q)$
26. Truth values differ when  $p$  is true and  $q$  is false.

27. Truth values differ when  $p$  is false and  $q$  is true.
28. No
29. Yes
30.  $(q \wedge (p \rightarrow \neg q)) \rightarrow \neg p \iff (q \wedge (\neg p \vee \neg q)) \rightarrow \neg p \iff ((q \wedge \neg p) \vee (q \wedge \neg q)) \rightarrow \neg p \iff (q \wedge \neg p) \rightarrow \neg p \iff \neg(q \wedge \neg p) \vee \neg p \iff (\neg q \vee p) \vee \neg p \iff \neg q \vee (p \vee \neg p)$ , which is always true.
31. No
32. Yes
33. If  $x$  is even, then  $y$  is odd.
34. If  $A$ , then  $B$ .
35. If it is sunny, then it is hot.
36. If you don't study, then you don't get a good grade (equivalently, if you get a good grade, then you study).
37. If you study, then you pass.
38. If the quarterback can pass, then the team wins.
39. If you are not registered, then you cannot check out library books (equivalently, if you check out library books, then you are registered).
40. Contrapositive: If you will not win, then you do not try hard. Converse: If you will win, then you try hard. Inverse: If you do not try hard, then you will not win.
41. Contrapositive: If you do not sleep late, then it is not Saturday. Converse: If you sleep late, then it is Saturday. Inverse: If it is not Saturday, then you do not sleep late.
42. It is not Thursday or it is not cold.
43. I will go to the play and read a book, or I will not go to the play and not read a book.
44. It is rainy and we do not go to the movies.
45. Both propositions can be false at the same time. For example, Al could be present and Bill absent.
46.  $\neg c \wedge \neg d$
47.  $\neg c \rightarrow r$
48.  $w \rightarrow c$
49.  $r \rightarrow (w \wedge c)$
50. "It is rainy or it is dry, but it cannot be both."
51.  $(r \wedge t) \rightarrow h$
52. Using  $m$ ,  $n$ ,  $k$ , and  $i$ , there are three rows of the truth table that have all five propositions true: the rows TTTT, FFTT, FFFT for  $m, n, k, i$ .
53. U.S. AND NATIONAL AND FOREST AND (NOT ALASKA) AND (NOT HAWAII)
54.  $A$  is a knight,  $B$  is a knave.
55.  $A$  is a knave,  $B$  is a knight.
56.  $A$  is the spy,  $B$  is the knight, and  $C$  is the knave.
57.  $A$  is the knave,  $B$  is the spy, and  $C$  is the knight.
58.  $A$  is the knight,  $B$  is the spy, and  $C$  is the knave, or  $A$  is the knave,  $B$  is the spy, and  $C$  is the knight.
59.  $\neg(\neg p \vee q) \wedge r$
60.  $\neg(p \wedge \neg q) \wedge (q \vee r)$

61.

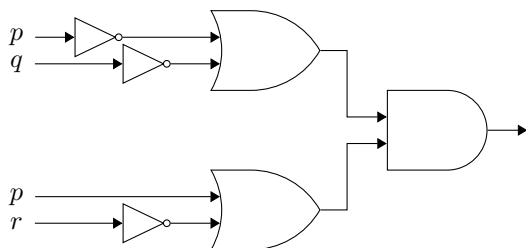

62.

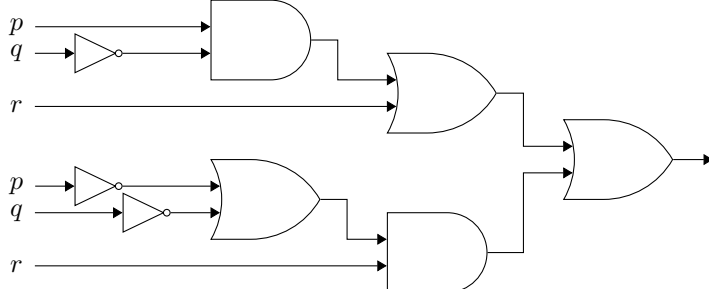
63. Setting  $p = \mathbf{F}$  and  $q = \mathbf{T}$  makes the compound proposition true; therefore it is satisfiable.64. Setting  $q = \mathbf{T}$  and  $p = \mathbf{F}$  makes the compound proposition true; therefore it is satisfiable.

65. False

66. False

67. True

68. True

69. True

70. True

71. False

72. False

73. False

74. False

75. False

76.  $\exists x((x \leq -1) \wedge (x \geq 1))$ 77.  $\forall x((3 \geq x) \vee (x > 7))$ 78. True. For every real number  $x$  we can find a real number  $y$  such that  $x + 2y = 5$ , namely  $y = (5 - x)/2$ .79. False. If it were true for some number  $x_0$ , then  $x_0 = 5 - 2y$  for every  $y$ , which is not possible.

80. True

81. False

82. True

83. True

84. True

85. False

86. True

87. False

88. False

89.  $T(\text{Eric, MTH 281})$ 90.  $\forall x F(x)$ 91.  $\forall x (F(x) \rightarrow B(x))$

92.  $\forall y (M(y) \rightarrow \neg U(y))$
93.  $\forall x \exists y T(x, y)$
94.  $\exists x \forall y [A(x) \wedge (M(y) \rightarrow \neg T(x, y))]$
95.  $\forall x \exists y [(F(x) \wedge A(x)) \rightarrow (U(y) \wedge T(x, y))]$
96. Mikko is a freshman.
97. Joe is not taking any course.
98. Some part-time students are not freshmen.
99. Every student is taking a course.
100. Some student is taking every course.
101. Every full-time freshman is taking a math course.
102.  $7 < 3$ .
103. There is no largest number.
104. No matter what positive number is chosen, there is a larger prime.
105.  $\forall x (I(x) \rightarrow E(x))$
106.  $\forall x \forall y (L(x, y) \rightarrow \neg Q(x, y))$
107.  $\forall x \exists y L(x, y)$
108.  $\exists x \neg G(x)$
109.  $\neg \exists x (I(x) \wedge E(x) \wedge \neg E(x))$
110.  $\exists x \neg A(x)$
111.  $\forall x (T(x) \rightarrow F(x))$
112.  $\forall x (F(x) \rightarrow \neg A(x))$
113.  $\exists x (T(x) \wedge A(x) \wedge F(x))$
114.  $\forall x (F(x) \rightarrow \neg A(x))$
115. Bill is angry.
116. No one is tall and angry.
117. Some friendly people are not angry.
118.  $\exists y \forall x (F(x) \rightarrow T(x, y))$
119.  $\neg \exists x (F(x) \wedge S(x))$
120.  $\exists x \exists y (F(x) \wedge A(y) \wedge T(x, y))$
121.  $\neg \exists x \forall y (A(y) \rightarrow T(x, y))$
122.  $\forall x (F(x) \rightarrow P(x, \text{calculus}))$
123. Wisteria did not pass MAT 100.
124. There is a course that all students are taking.
125. Every student is taking at least one course.
126.  $\forall y (C(y) \rightarrow \neg A(y))$
127.  $S(\text{Lois}, \text{Casablanca}) \wedge \neg L(\text{Lois}, \text{Casablanca})$
128.  $\exists x \forall y [C(y) \rightarrow S(x, y)]$
129.  $\neg \exists x \forall y [S(x, y) \rightarrow L(x, y)]$
130.  $\neg \exists y [A(y) \wedge S(\text{Ben}, y)]$
131. There is a movie that Margaret did not see.
132. There is a movie that everyone liked.
133. Everyone liked at least one movie.

134. 6
135. 1, 10
136. 12
137. 2
138. 3
139. 7
140. 5, 8, 11
141. 9
142. 7
143. 4
144. 3
145. 2
146. 3
147. 2
148. 1
149. 1
150. 2
151. 3
152. 2
153. 3
154. 1
155.  $\exists A \neg F(A)$
156.  $\forall A \forall B [(F(B) \wedge S(A, B)) \rightarrow F(A)]$
157.  $\neg \exists A \exists B (\neg F(A) \wedge F(B) \wedge S(A, B))$
158.  $\forall A (F(A) \rightarrow S(\emptyset, A))$
159. No bananas are yellow.
160. Some integers ending in the digit 7 are not odd.
161. Some tests are easy.
162. Roses are not red or violets are not blue.
163. All skiers speak Swedish.
164. (a) Depending on which word is emphasized, the sentence can be interpreted as “all bananas are non-ripe fruit” (i.e., no bananas are ripe) or as “not all bananas are ripe” (i.e., some bananas are not ripe).  
 (b) Both statements can be false at the same time.  
 (c) Both statements can be true at the same time.  
 (d) Some bananas are not ripe.
165. Both statements can be true at the same time.
166. Modus tollens
167. Hypothetical syllogism
168. Setting  $p$  false and  $q$  true yield true hypotheses but a false conclusion.
169. Not valid:  $p$  false,  $q$  false,  $r$  true
170. Not valid:  $p$  true,  $q$  true,  $r$  true
171. Use resolution on  $l \vee f$  and  $\neg l \vee r$  to conclude  $f \vee r$ .

172. Not valid: fallacy of affirming the conclusion
173. Not valid: fallacy of denying the hypothesis
174. Valid
175. Valid
176. Not valid
177. Universal instantiation
178. Universal instantiation
179. The two premises do not imply the conclusion.
180. Let  $R(x)$  be the predicate “ $x$  has read the textbook” and  $P(x)$  be the predicate “ $x$  passed the exam.” The following is the proof:
1.  $\forall x (R(x) \rightarrow P(x))$  hypothesis
  2.  $R(\text{Ed}) \rightarrow P(\text{Ed})$  universal instantiation on 1
  3.  $R(\text{Ed})$  hypothesis
  4.  $P(\text{Ed})$  modus ponens on 2 and 3
181. The two premises do not imply the conclusion.
182. Existential generalization
183. (a) Assume  $p$ , prove  $q$ .  
 (b) Assume  $\neg q$ , prove  $\neg p$ .  
 (c) Assume  $p \wedge \neg q$ , show that this leads to a contradiction.
184. Direct proof: Assume  $p$ , show  $q$ . Indirect proof: Assume  $\neg q$ , show  $\neg p$ .
185. Suppose  $x = 2k + 1$ ,  $y = 2l$ . Therefore  $x + y = 2k + 1 + 2l = 2(k + l) + 1$ , which is odd.
186. Suppose  $n = 2k + 1$  but  $n^2 = 2l$ . Therefore  $(2k + 1)^2 = 2l$ , or  $4k^2 + 4k + 1 = 2l$ . Hence  $2(2k^2 + 2k - l) = -1$  (even = odd), a contradiction. Therefore  $n^2$  is odd.
187. Let  $x = 2k + 1$ ,  $y = 2l + 1$ . Therefore  $x + y = 2k + 1 + 2l + 1 = 2(k + l + 1)$ , which is even.
188. Suppose  $x = 2k + 1$  and  $y = 2l + 1$ , but  $x + y = 2m + 1$ . Therefore  $(2k + 1) + (2l + 1) = 2m + 1$ . Hence  $2(k + l - m + 1) = 1$  (even = odd), which is a contradiction. Therefore  $x + y$  is even.
189. Suppose  $x = 2k$  and  $y = 2l$ , but  $xy = 2m + 1$ . Therefore  $2k \cdot 2l = 2m + 1$ . Hence  $2(2kl - m) = 1$  (even = odd), which is a contradiction. Therefore  $xy$  is even.
190. Let  $x = 2k + 1$ . Therefore  $x + 2 = 2k + 1 + 2 = 2(k + 1) + 1$ , which is odd.
191. Suppose  $x + 2 = 2k$ . Therefore  $x = 2k - 2 = 2(k - 1)$ , which is even.
192. Suppose  $x$  is odd but  $x + 2$  is even. Therefore  $x = 2k + 1$  and  $x + 2 = 2l$ . Hence  $(2k + 1) + 2 = 2l$ . Therefore  $2(k + 1 - l) = -1$  (even = odd), a contradiction.
193. Let  $n = 2k$ . Therefore  $n + 1 = 2k + 1$ , which is odd.
194. Suppose  $n + 1$  is even. Therefore  $n + 1 = 2k$ . Therefore  $n = 2k - 1 = 2(k - 1) + 1$ , which is odd.
195. Suppose  $n = 2k$  but  $n + 1 = 2l$ . Therefore  $2k + 1 = 2l$  (even = odd), which is a contradiction.
196. If  $n$  is even, then  $n = 2k$ . Therefore  $3n^2 + 8 = 3(2k)^2 + 8 = 12k^2 + 8 = 2(6k^2 + 4)$ , which is even. If  $n$  is odd, then  $n = 2k + 1$ . Therefore  $3n^2 + 8 = 3(2k + 1)^2 + 8 = 12k^2 + 12k + 11 = 2(6k^2 + 6k + 5) + 1$ , which is odd.
197. If  $n$  is even, then  $n^2 = (2k)^2 = 2(2k^2)$ , which is even. If  $n$  is odd, then  $n^2 = (2k + 1)^2 = 2(2k^2 + 2k) + 1$ , which is odd.
198. If  $m = 2k$  and  $n = 2l$ , then  $mn = 4kl$ . Hence  $mn$  is a multiple of 4.
199. False:  $x = 2$ ,  $y = 1/2$
200. False:  $x = 1/2$
201. False:  $x = 3/2$ ,  $y = 3/2$

- 202.** Case 1,  $x \geq 0$ : then  $x = |x|$ , so  $x \leq |x|$ . Case 2,  $x < 0$ : here  $x < 0$  and  $0 < |x|$ , so  $x < |x|$ .
- 203.** We prove the statement by cases. The two cases  $1 \leq x \leq 5$  or  $x \geq 6$  are exhaustive. In the first case, if  $1 \leq x \leq 5$ , then  $x^2 \leq 25$  so  $x^2 \neq 27$ . In the second case, if  $x \geq 6$ , then  $x^2 \geq 36$  and  $x^2 \neq 27$ . So  $x^2 \neq 27$  for all positive integers  $x$  and we conclude that 27 is not a perfect square.
- 204.** It is easier to give a contraposition proof; it is usually easier to proceed from a simple expression (such as  $n$ ) to a more complex expression (such as  $3n + 5$  is even). Begin by supposing that  $n$  is not odd. Therefore  $n$  is even and hence  $n = 2k$  for some integer  $k$ . Therefore  $3n + 5 = 3(2k) + 5 = 6k + 5 = 2(3k + 2) + 1$ , which is not even. If we try a direct proof, we assume that  $3n + 5$  is even; that is,  $3n + 5 = 2k$  for some integer  $k$ . From this we obtain  $n = (2k - 5)/3$ , and it is not obvious from this form that  $n$  is even.
- 205.** Prove that (a) and (b) are equivalent and that (a) and (c) are equivalent.
- 206.** If at most three people were born in each of the 12 months of the year, there would be at most 36 people.
- 207.** Give a proof by cases. There are only six cases that need to be considered:  $x = y = 1$ ;  $x = 1, y = 2$ ;  $x = 1, y = 3$ ;  $x = 2, y = 1$ ;  $x = y = 2$ ;  $x = 2, y = 3$ .
- 208.** The steps in the “proof” cannot be reversed. Knowing that the squares of two numbers,  $-3$  and  $3$ , are equal does not allow us to infer that the two numbers are equal.

## Questions for Chapter 2

For each of the pairs of sets in 1–3 determine whether the first is a subset of the second, the second is a subset of the first, or neither is a subset of the other.

- The set of people who were born in the U.S., the set of people who are U.S. citizens.
- The set of students studying a programming language, the set of students studying Java.
- The set of animals living in the ocean, the set of fish.
- Prove or disprove:  $A - (B \cap C) = (A - B) \cup (A - C)$ .
- Prove that  $\overline{A \cap B} = \overline{A} \cup \overline{B}$  by giving a containment proof (that is, prove that the left side is a subset of the right side and that the right side is a subset of the left side).
- Prove that  $\overline{A \cap B} = \overline{A} \cup \overline{B}$  by giving an element table proof.
- Prove that  $\overline{A \cap B} = \overline{A} \cup \overline{B}$  by giving a proof using logical equivalence.
- Prove that  $\overline{A \cap B} = \overline{A} \cup \overline{B}$  by giving a Venn diagram proof.
- Prove that  $A \cap (B \cup C) = (A \cap B) \cup (A \cap C)$  by giving a containment proof (that is, prove that the left side is a subset of the right side and that the right side is a subset of the left side).
- Prove that  $A \cap (B \cup C) = (A \cap B) \cup (A \cap C)$  by giving an element table proof.
- Prove that  $A \cap (B \cup C) = (A \cap B) \cup (A \cap C)$  by giving a proof using logical equivalence.
- Prove that  $A \cap (B \cup C) = (A \cap B) \cup (A \cap C)$  by giving a Venn diagram proof.
- Prove or disprove: if  $A, B$ , and  $C$  are sets, then  $A - (B \cap C) = (A - B) \cap (A - C)$ .
- Prove or disprove  $A \oplus (B \oplus C) = (A \oplus B) \oplus C$ .

In questions 15–18 use a Venn diagram to determine which relationship,  $\subseteq$ ,  $=$ , or  $\supseteq$ , is true for the pair of sets.

- $A \cup B, A \cup (B - A)$
- $A \cup (B \cap C), (A \cup B) \cap C$
- $(A - B) \cup (A - C), A - (B \cap C)$
- $(A - C) - (B - C), A - B$

In questions 19–23 determine whether the given set is the power set of some set. If the set is a power set, give the set of which it is a power set.

- $\{\emptyset, \{\emptyset\}, \{a\}, \{\{a\}\}, \{\{\{a\}\}\}, \{\emptyset, a\}, \{\emptyset, \{a\}\}, \{\emptyset, \{\{a\}\}\}, \{a, \{a\}\}, \{a, \{\{a\}\}\}, \{\{a\}, \{\{a\}\}\}, \{\emptyset, a, \{a\}\}, \{\emptyset, a, \{\{a\}\}\}, \{\emptyset, \{a\}, \{\{a\}\}\}, \{a, \{a\}, \{\{a\}\}\}, \{\emptyset, a, \{a\}, \{\{a\}\}\}$
- $\{\emptyset, \{a\}\}$